

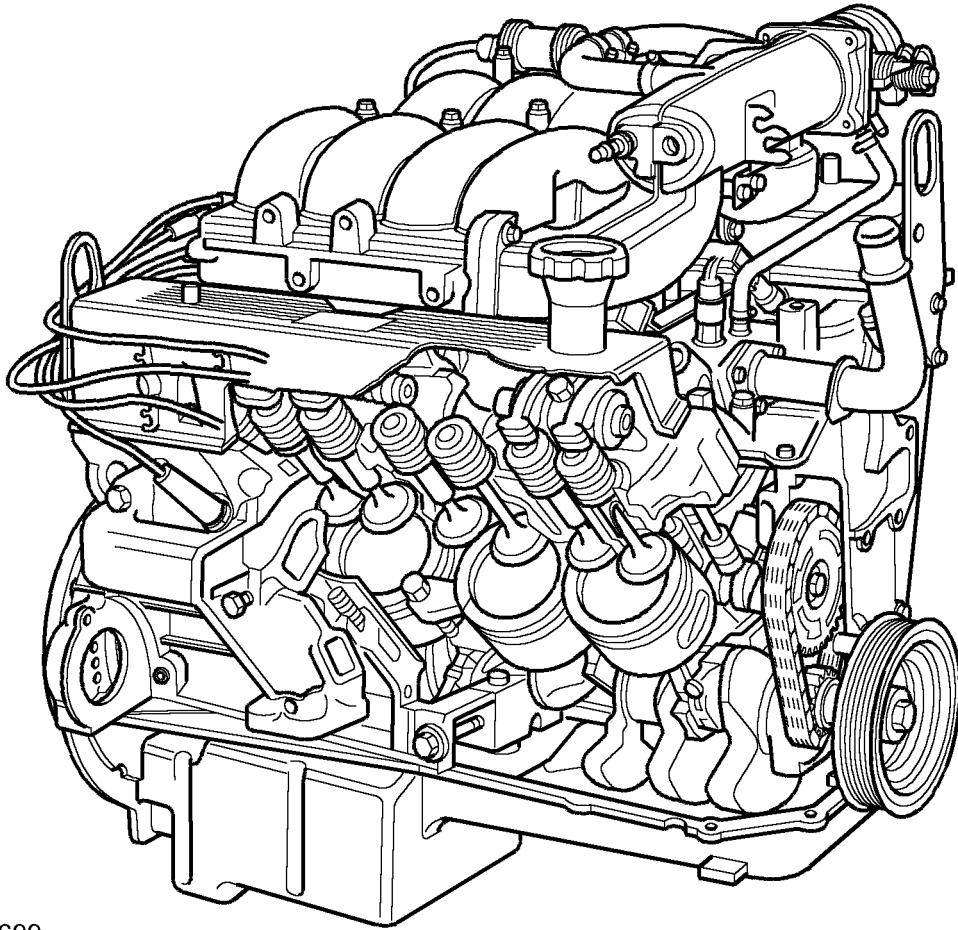

V8 Engine



M12 4699

ENGINE - V8

Cylinder head components

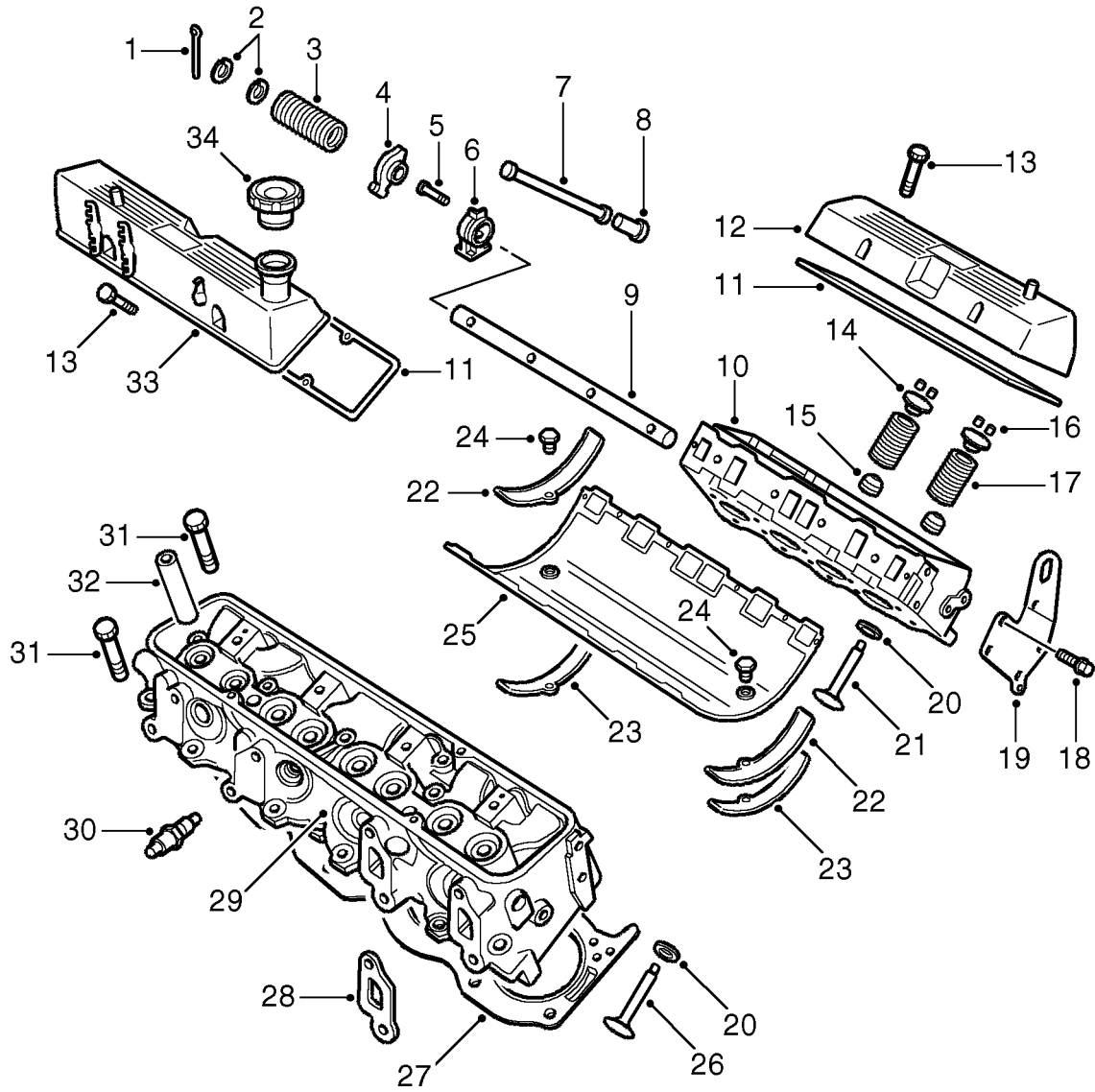

M12 4697



- 1 Split pin
- 2 Washers
- 3 Spring
- 4 Rocker arm
- 5 Pedestal bolt
- 6 Pedestal
- 7 Push rod
- 8 Hydraulic tappet
- 9 Rocker shaft
- 10 Cylinder head - left hand
- 11 Gasket - rocker cover
- 12 Rocker cover - left hand
- 13 Bolt - rocker cover
- 14 Valve spring cap
- 15 Valve stem oil seals
- 16 Collets
- 17 Valve spring
- 18 Bolt - engine lifting bracket
- 19 Engine lifting bracket
- 20 Valve seat insert
- 21 Exhaust valve
- 22 Clamp - inlet manifold gasket
- 23 Seal - inlet manifold gasket
- 24 Bolt - inlet manifold gasket clamp
- 25 Gasket - inlet manifold
- 26 Inlet valve
- 27 Gasket - cylinder head
- 28 Gasket - exhaust manifold
- 29 Cylinder head - right hand
- 30 Spark plug
- 31 Bolt - cylinder head
- 32 Valve guide
- 33 Rocker cover - right hand
- 34 Engine oil filler cap

Cylinder block components

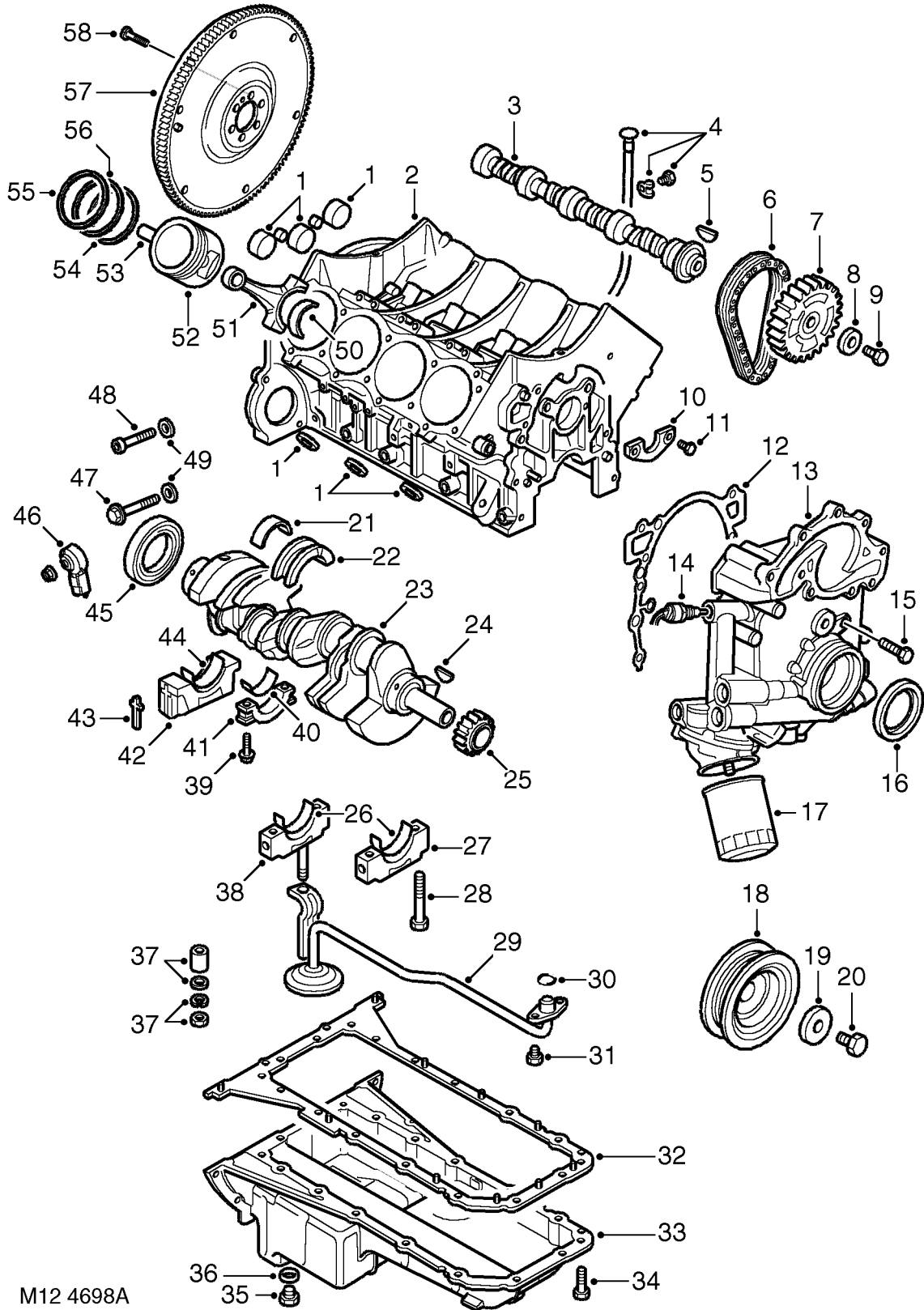

M12 4698A



- 1 Core plugs
- 2 Cylinder block
- 3 Camshaft
- 4 Dipstick tube, clamp and bolt
- 5 Woodruff key
- 6 Timing chain
- 7 Camshaft timing gear
- 8 Washer
- 9 Bolt - camshaft timing gear
- 10 Thrust plate - camshaft end-float
- 11 Bolt - camshaft thrust plate
- 12 Gasket - timing cover
- 13 Timing cover
- 14 Oil pressure switch
- 15 Bolt
- 16 Crankshaft front oil seal
- 17 Oil filter element
- 18 Crankshaft front pulley
- 19 Washer
- 20 Bolt - crankshaft front pulley
- 21 Upper main bearing shell
- 22 Upper centre main bearing shell and thrust washer
- 23 Crankshaft
- 24 Woodruff key
- 25 Crankshaft timing gear
- 26 Lower main bearing shells
- 27 Numbers 1, 2 and 3 main bearing caps
- 28 Bolt - main bearing caps
- 29 Oil pick-up pipe and strainer
- 30 'O' ring
- 31 Bolt - oil pick-up pipe
- 32 Gasket - sump
- 33 Sump
- 34 Bolt - sump
- 35 Sump oil drain plug
- 36 Sealing washer
- 37 Spacer, washers and nut - oil pick-up pipe
- 38 Number 4 main bearing cap
- 39 Bolt - connecting rod big-end bearing cap
- 40 Connecting rod big-end bearing shell - lower
- 41 Connecting rod big-end bearing cap
- 42 Number 5 - rear main bearing cap
- 43 Cruciform seal - rear main bearing cap
- 44 Number 5 - rear main bearing shell
- 45 Crankshaft rear oil seal
- 46 Crankshaft knock sensor
- 47 Side bolt - main bearing cap
- 48 Side Allen bolt - main bearing cap
- 49 Dowty washers
- 50 Connecting rod big-end bearing shell - upper
- 51 Connecting rod
- 52 Piston
- 53 Gudgeon pin
- 54 Oil control ring
- 55 Top compression ring
- 56 2nd compression ring
- 57 Flywheel/drive plate and starter ring gear
- 58 Bolt - flywheel/drive plate

ENGINE - V8

Description

General

The V8 petrol engine is an eight cylinder, water cooled unit having two banks of four cylinders positioned at 90 degrees to each other. The engine comprises five main castings - two cylinder heads, cylinder block, timing cover and the oil sump, all of which are manufactured from aluminium alloy.

Cylinder heads

The cylinder heads are fitted with replaceable valve guides and valve seat inserts with the combustion chambers formed in the head. Each cylinder head is sealed to the cylinder block with a gasket. The exhaust manifolds are bolted to the outside of each cylinder head whilst the inlet manifolds are located in the centre of the 'Vee' and are bolted to the inside face of each head. Inlet and exhaust manifolds are sealed to the cylinder heads by means of gaskets.

Each cylinder has a single inlet and exhaust valve. The exhaust valves are of the 'carbon break' type, a recess on the valve stem prevents a build-up of carbon in the valve guide by dislodging particles of carbon as the valve stem moves up and down the guide. Inlet and exhaust valve stem oil seals are fitted at the top of each valve guide. Valve operation is by means of rocker arms, push rods and hydraulic tappets. Each of the rocker arms is located on a rocker shaft which is supported by means of pedestals bolted to the cylinder heads. A spring, positioned on either side of each rocker arm, maintains the correct relative position of the arm to its valve stem. The rocker arms are operated directly by the push rods which pass through drillings in the cylinder heads and cylinder block. The bottom end of each push rod locates in a hydraulic tappet operated by the single, chain driven camshaft.

The rocker covers are bolted to the cylinder heads and are sealed to the heads by a rubber gasket. Stub pipes for crankcase ventilation hose connections are fitted to each rocker cover, the pipe in the right hand cover incorporates an oil separator. The engine oil filler cap is situated in the right hand cover.

Cylinder block and camshaft

The cylinder block is fitted with cast iron cylinder liners which are shrink fitted and locate on stops in the block. The camshaft is positioned in the centre of the cylinder block and runs in one piece bearing shells which are line bored after fitting. Camshaft end-float is controlled by a thrust plate bolted to the front of the cylinder block. A timing gear, chain driven by the crankshaft timing gear is bolted to the front of the camshaft.

Crankshaft and main bearings

The crankshaft is carried in five main bearings. The upper main bearing shell locations are an integral part of the cylinder block casting. The lower main bearing caps are bolted to the cylinder block on either side of the upper bearing shell locations with an additional bolt being inserted into each cap from either side of the cylinder block. The rear main bearing cap carries the crankshaft rear oil seal and is sealed to the cylinder block by means of cruciform shaped seals in each side of the cap. Number four main bearing cap carries the stud fixing for the oil pick-up pipe. Lower main bearing shells are plain whilst the upper shells have an oil feed hole and are grooved. Crankshaft end-float is controlled by the thrust faces of the upper centre shell. The crankshaft timing gear is located on the front of the crankshaft by means of a Woodruff key which is also used to drive the gear type oil pump. The flywheel/drive plate carries the crankshaft position sensor reluctor ring and is dowel located and bolted to the flywheel.

Timing cover

The timing cover is bolted to the front of the cylinder block and is sealed to the block with a gasket. The disposable, full flow oil filter canister is screwed on to the timing cover which also carries the oil pressure switch, oil pressure relief valve and crankshaft front oil seal. The gear type oil pump is integral with the cover which also has an internal oilway to direct oil from the oil cooler to the filter.

Oil sump

The oil sump is bolted to the bottom of the cylinder block and the timing cover and is sealed to both components with a one piece gasket. A removable baffle to prevent oil surge is fitted in the sump. The oil pick-up pipe and strainer assembly is positioned within the sump and is attached at the pick-up end to a stud screwed into number four main bearing cap and at the delivery end to the oil pump. The oil drain plug is located in the bottom of the sump and is sealed with a washer.



Pistons and connecting rods

Each of the aluminium alloy pistons has two compression rings and an oil control ring. The pistons are secured to the connecting rods by semi-floating gudgeon pins. Each gudgeon pin is offset by 0.5 mm (0.02 in). The top of each piston is recessed, the depth of recess determining the compression ratio of the engine. Plain, big-end bearing shells are fitted to each connecting rod and cap.

ENGINE - V8

Lubrication

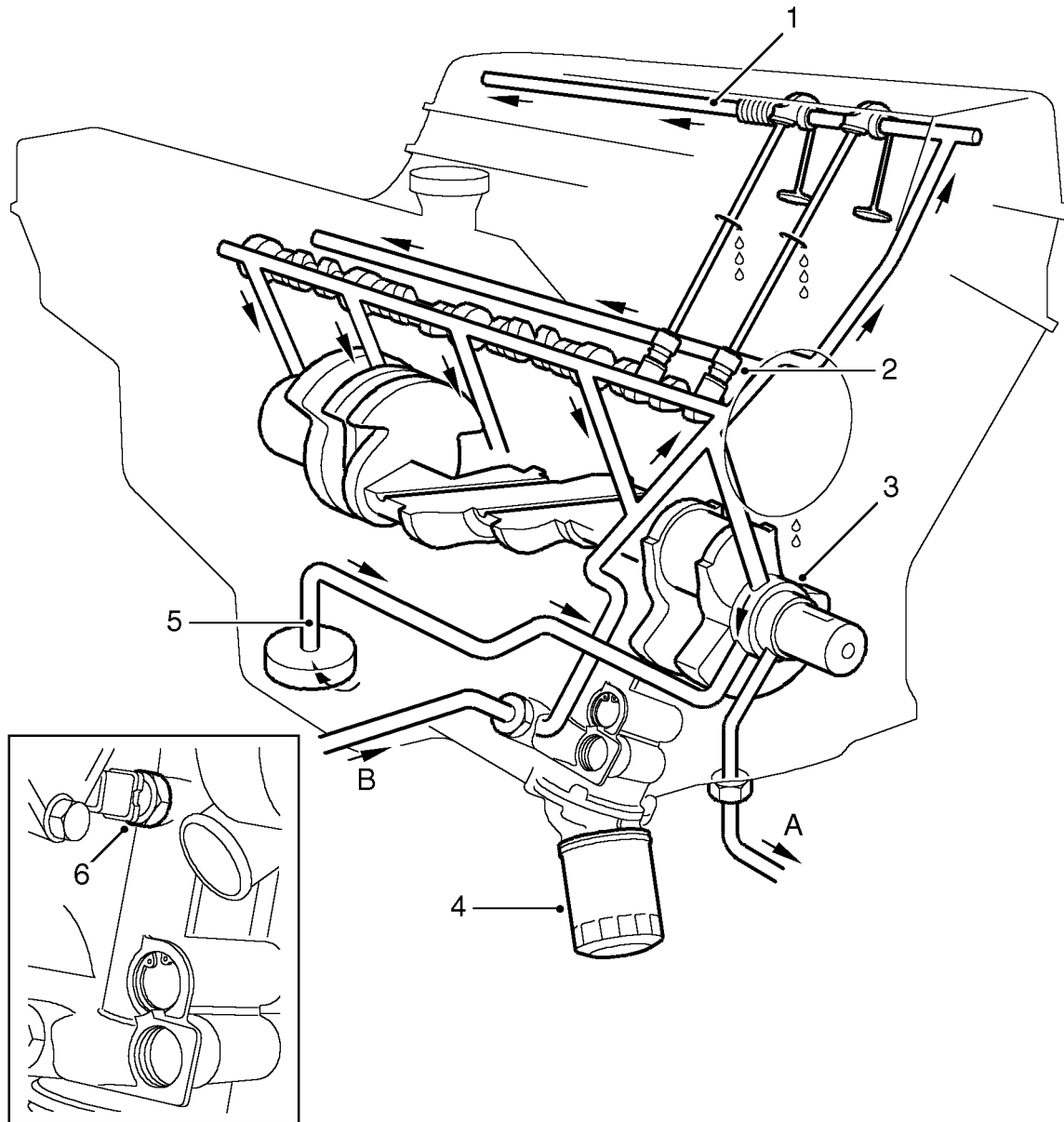

M12 4700A

A - To oil cooler, B - From oil cooler

- 1 Rocker shaft assembly
- 2 Hydraulic tappet
- 3 Oil pump
- 4 Oil filter element
- 5 Oil pick-up pipe and strainer
- 6 Oil pressure switch

Oil is drawn from the sump through a strainer and into the oil pump via the oil pick-up pipe. Pressurised oil from the pump passes through the oil cooler mounted in front of the radiator and returns to the full flow oil filter element. Oil from the filter passes into the main oil gallery and through internal drillings to the crankshaft where it is directed to



each main bearing and to the big-end bearings via numbers 1, 3 and 5 main bearings. An internal drilling in the cylinder block directs oil to the camshaft where it passes through further internal drillings to the hydraulic tappets, camshaft bearing journals and rocker shafts. Lubrication to the pistons, small ends and cylinder bores is by oil grooves machined in the connecting rods and by splash.

Oil pressure switch

The oil pressure warning light switch registers low oil pressure in the main oil gallery on the outflow side of the filter. Whilst the engine is running and oil pressure is correct, the switch is open. When the ignition is switched on or if oil pressure drops below the pressure setting of the switch, the switch closes and the low oil pressure warning lamp located in the instrument pack will illuminate.

Hydraulic tappets

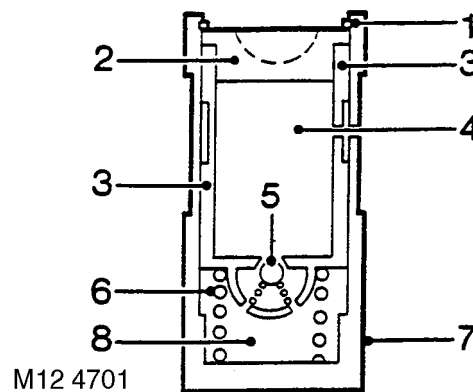

- 1 Clip
- 2 Pushrod seat
- 3 Inner sleeve
- 4 Upper chamber
- 5 Non-return ball valve
- 6 Spring
- 7 Outer sleeve
- 8 Lower chamber

The hydraulic tappet provides maintenance free, quiet operation of the valves. This is achieved by utilizing engine oil pressure to eliminate the clearance between the rocker arms and valve stems. When the valve is closed, engine oil pressure present in the upper chamber, passes through the non-return ball valve and into the lower chamber. When the cam begins to lift the outer sleeve, the resistance of the valve spring, felt through the push rod and seat, causes the tappet inner sleeve to move downwards inside the outer sleeve. This downwards movement closes the non-return ball valve and increases the pressure in the lower chamber sufficiently to ensure that the valve is fully opened by the push rod. As the tappet moves off the peak of the cam, the non-return ball valve opens thereby allowing the pressure in both chambers to equalize. This ensures that the valve will be fully closed when the tappet is on the back of the cam.

Crankcase ventilation

A positive crankcase ventilation system is used to vent crankcase gases to the air induction system. Gases are drawn from the left hand rocker cover to a tapping in the throttle body. An oil separator is incorporated in the hose connection stub pipe in the right hand rocker cover, gases from this connection are drawn to a tapping in the inlet manifold.

 **EMISSION CONTROL - V8, DESCRIPTION AND OPERATION, Crankcase emission control system.**